

**ASME B18.2.6-2006**  
[Revision of ASME B18.2.6-1996 (R2004)]

# **Fasteners for Use in Structural Applications**

**AN AMERICAN NATIONAL STANDARD**



**The American Society of  
Mechanical Engineers**

**ASME B18.2.6-2006**

**[Revision of ASME B18.2.6-1996 (R2004)]**

# **Fasteners for Use in Structural Applications**

**AN AMERICAN NATIONAL STANDARD**



**The American Society of  
Mechanical Engineers**

**Three Park Avenue • New York, NY 10016**

Date of Issuance: June 16, 2006

This Standard will be revised when the Society approves the issuance of a new edition. There will be no addenda issued to this edition.

ASME issues written replies to inquiries concerning interpretations of technical aspects of this Standard. Interpretations are published on the ASME website under the Committee Pages at <http://www.asme.org/codes/> as they are issued.

ASME is the registered trademark of The American Society of Mechanical Engineers.

This code or standard was developed under procedures accredited as meeting the criteria for American National Standards. The Standards Committee that approved the code or standard was balanced to assure that individuals from competent and concerned interests have had an opportunity to participate. The proposed code or standard was made available for public review and comment that provides an opportunity for additional public input from industry, academia, regulatory agencies, and the public-at-large.

ASME does not “approve,” “rate,” or “endorse” any item, construction, proprietary device, or activity.

ASME does not take any position with respect to the validity of any patent rights asserted in connection with any items mentioned in this document, and does not undertake to insure anyone utilizing a standard against liability for infringement of any applicable letters patent, nor assume any such liability. Users of a code or standard are expressly advised that determination of the validity of any such patent rights, and the risk of infringement of such rights, is entirely their own responsibility.

Participation by federal agency representative(s) or person(s) affiliated with industry is not to be interpreted as government or industry endorsement of this code or standard.

ASME accepts responsibility for only those interpretations of this document issued in accordance with the established ASME procedures and policies, which precludes the issuance of interpretations by individuals.

No part of this document may be reproduced in any form,  
in an electronic retrieval system or otherwise,  
without the prior written permission of the publisher.

The American Society of Mechanical Engineers  
Three Park Avenue, New York, NY 10016-5990

Copyright © 2006 by  
THE AMERICAN SOCIETY OF MECHANICAL ENGINEERS  
All rights reserved  
Printed in U.S.A.

# CONTENTS

Foreword .....	iv
Committee Roster .....	vi
Correspondence With the B18 Committee .....	vii
<b>1 Introductory Notes .....</b>	<b>1</b>
<b>2 Heavy Hex Structural Bolts: ASTM A 325 or ASTM A 490 .....</b>	<b>2</b>
<b>3 Heavy Hex Nuts: ASTM A 563.....</b>	<b>5</b>
<b>4 Hardened Steel Washers.....</b>	<b>7</b>
<b>5 Compressible Washer-Type Direct Tension Indicators .....</b>	<b>10</b>
<b>6 Twist-Off-Type Tension Control Structural Bolts: Heavy Hex and Round: ASTM F 1852.....</b>	<b>11</b>
<b>Figure</b>	
1 Groove Diameter .....	13
<b>Tables</b>	
1 Dimensions of Heavy Hex Structural Bolts .....	2
2 Maximum Grip Gaging Lengths and Minimum Body Lengths for Heavy Hex Structural Bolts .....	4
3 Dimensions of Heavy Hex Nuts for Use With Structural Bolts .....	6
4 Dimensions for Hardened Steel Circular and Circular Clipped Washers .....	8
5 Dimensions of Hardened Beveled Washers With Slope or Taper in Thickness 1:6 .....	9
6 Dimensions for Compressible Washer-Type Direct Tension Indicators .....	10
7 Dimensions of Twist-Off-Type Tension Control Structural Bolts Heavy Hex Head and Round Head Configurations .....	12

# FOREWORD

American National Standards Committee B18 for the standardization of bolts, screws, nuts, rivets, and similar fasteners was organized in March 1922 as Sectional Committee B18, under the aegis of the American Engineering Standards Committee (later the American Standards Association, then the United States of America Standards Institute and, as of October 6, 1969, the American National Standards Institute, Inc.), with the Society of Automotive Engineers and the American Society of Mechanical Engineers as joint sponsors. Subcommittee 2 was subsequently established and charged with the responsibility for technical content of standards covering wrench head bolts and nuts.

Subcommittee 2, after appraisal of the requirements of industry, developed a proposed standard series of bolt head and nut dimensions. This proposal was finally approved and designated a Tentative American Standard in February 1927.

A first revision of the document was designated as an American Standard in March 1933, and was followed by a second revision, which was granted approval as an American Standard in January 1941.

Following reorganization of the B18 Committee in 1947, Subcommittee 2 was asked to expand the standard on head proportions into a complete product standard. A proposal covering square and hexagon head bolts and nuts, hexagon head cap screws, and automotive hexagon head bolts was prepared and submitted to the B18 Committee in April 1950. While this draft was under consideration, the B18 Committee received a proposal from the British Standards Institution for unification of dimensions on products incorporating unified screw threads. The Committee welcomed the opportunity of discussing the proposals and an American-British-Canadian Conference was held in New York, June 1-2, 1950.

It was agreed in the Conference that the essentials of unification could be accomplished by selection of mutually satisfactory across-the-flats dimensions, since this would permit the use of the same wrenches and because other features would rarely affect interchangeability. After due consideration, suitable existing across-the-flats dimensions were selected for the hexagon products affected.

In its meeting of October 13, 1950, Subcommittee 2 agreed to incorporate in the proposed standard the conference recommendations on  $\frac{1}{4}$  in. hexagon head bolts,  $\frac{5}{8}$  in. hexagon head cap screws and automotive hexagon head bolts,  $\frac{5}{16}$  in. and  $\frac{3}{8}$  in. regular hexagon and square nuts, and  $\frac{7}{16}$  in. light and regular hexagon and square nuts. At a subsequent meeting of Subcommittee 2, further changes were adopted in order to combine the light and regular series of nuts and to combine the automotive hexagon head bolt, hexagon head cap screw, and regular hexagon head close tolerance bolt.

In view of the progress made in the United States and the urgency of standardization for mutual defense, the British Standards Institution sponsored a second Conference in London in April 1951 to complete the unification of certain hexagon bolts and nuts.

At a meeting on June 8, 1951, Subcommittee 2 reaffirmed its acceptance of the unified dimensions, which corresponded with those in the March 1951 draft, but attempted to select better nomenclature for the unified products. A final draft incorporating the nomenclature *Finished Hexagon Bolts and Nuts* and containing numerous editorial changes was submitted for letter ballot in September 1951. Following approval by the B18 Committee and the sponsors, the proposal was presented to the American Standards Association for approval and designation as an American Standard. This was granted on March 24, 1952.

Recognizing the standard was in need of additional refinements, Subcommittee 2 began immediately to revise it: removing inconsistencies with respect to fillets, improving the length tolerances on heavy hexagon bolts, and incorporating numerous other corrections and clarifications. The most noteworthy editorial change was a decision to combine the coverage for hexagon cap screws and square head set screws from the B18.2 standard with the coverage for slotted head cap screws and slotted headless set screws from the B18.6 standard and publish them in a separate document.

The requirements for the unified hexagon cap screws and finished hexagon bolts being identical in the overlapping sizes, this data would now be available in two publications. Following approvals by the B18 Committee and sponsor organizations, the proposal was submitted to the American Standards Association and declared an American Standard on February 2, 1955.

A revision of this document comprised of numerous editorial corrections and inclusions of an appendix for grade markings was duly approved and designated an American Standard on April 18, 1960.

At a meeting in February 1960, Subcommittee 2 approved a recommendation to reduce the head heights for heavy, heavy semifinished, and heavy finished hexagon bolts which was subsequently approved by letter ballot of the B18 Committee on August 16, 1960. A proposed standard for heavy hexagon structural bolts submitted and accepted by Subcommittee 2 at its October 17, 1960 meeting was approved by letter ballot of the B18 Committee on May 9, 1961. To meet the urgent needs of the steel construction industry, it was considered necessary to publish the standard for the structural bolts immediately. Consequently, Appendix IV to ASA B18.2-1960 containing coverage for the revised heavy hexagon bolts and the new heavy hexagon structural bolts was released in 1962.

In October of 1961 Subcommittee 2 appointed a subgroup to review all product standards for square and hexagon bolts, screws, and nuts, and to recommend simplifications which would be compatible with technical, production, and distribution advances that had occurred over the prior several years. The subgroup presented its recommendations at a meeting of Subcommittee 2 in October 1962. It was agreed that the internally and externally threaded products should be published in separate documents as suggested, and draft proposals for each were completed.

The proposed revision for square and hex bolts and screws incorporated the following subgroup recommendations: consolidation of hexagon head cap screws and finished hexagon bolts into a single product, consolidation of heavy semifinished hexagon bolts and heavy finished hexagon bolts into a single product, elimination of regular semifinished hexagon bolts, a new length tolerancing pattern for all bolts and screws, documentation of a positive identification procedure for determining whether an externally threaded product should properly be designated a bolt or a screw, and an abbreviated and purified set of product nomenclature reflecting application of the identification procedure. Letter ballot of this proposal to the B18 Committee in March 1964 resulted in several comments, which were resolved to the satisfaction of the Committee in June 1964. Following acceptance by the sponsor organizations, the revision was submitted to the American Standards Association and was designated American Standard ASA B18.2.1 on September 8, 1965.

Subcommittee 2 in 1992 recognized the value of having all structural products in a single standard. In a revision initiated for the B18.2.1 standard in that year, it was proposed to remove the heavy hex structural bolt from the B18.2.1 standard, the heavy hex nut from the B18.2.2 standard and combine these with the dimensions of hardened steel washers from ASTM F 436 and the compressible-washer-type direct tension indicator dimensions of ASTM F 959. This new standard would then provide all standardized dimensions for the fasteners intended for use in structural applications. The first draft of this Standard was submitted to Subcommittee 2 at its May 1993 meeting.

The American National Standards Institute (ANSI) approved the previous edition, ASME B18.2.6-1996, on December 4, 1996.

This revision was approved by the American National Standards Institute (ANSI) on February 24, 2006.

# ASME B18 COMMITTEE

## Standardization of Bolts, Nuts, Rivets, Screws, Washers, and Similar Fasteners

(The following is the roster of the Committee at the time of approval of this Standard.)

### STANDARDS COMMITTEE OFFICERS

**D. A. Clever**, *Chair*  
**R. D. Strong**, *Vice Chair*  
**S. W. Vass**, *Vice Chair*  
**R. L. Crane**, *Secretary*

### STANDARDS COMMITTEE PERSONNEL

**J. B. Belford**, Lawson Products, Inc.  
**V. Cartina**, Aztech Locknut  
**D. A. Clever**, Deere and Co.  
**A. P. Cockman**, Ford Motor Co.  
**R. L. Crane**, The American Society of Mechanical Engineers  
**A. C. DiCola**, Wrought Washer Co.  
**B. A. Dusina**, Federal Screw Works  
**J. S. Foote**, *Corresponding Member*, Trade Association Management, Inc.  
**D. S. George**, Ford Motor Co.  
**J. Greenslade**, Greenslade and Co.  
**J. J. Grey**, Fastener Consulting Services, Inc.  
**B. Hasiuk**, Defense Industrial Supply Center Philadelphia  
**A. Herskovitz**, Consultant  
**J. Hubbard**, Rockford Fastener, Inc.  
**J. Jennings**, *Corresponding Member*, Naval Surface Warfare Center  
**M. Keller**, *Corresponding Member*, Paracad Technology Co.  
**J. F. Koehl**, Spirol International Corp.

**W. H. Kopke**, ITW Shakeproof Assembly Components  
**J. G. Langenstein**, *Member Emeritus*, Consultant  
**W. J. Lutkus**, Emhart Industrial Heli-Coil  
**D. McCrindle**, Canadian Fasteners Institute  
**M. D. Prasad**, General Motors Corp.  
**J. A. Roley**, *Corresponding Member*, Caterpillar, Inc.  
**W. L. Sakowski**, Account Managers, LLC  
**S. Savoji**, ITW Medalist  
**W. Schevey**, BGM Fastener Co., Inc.  
**W. R. Stevens**, Ramco  
**R. D. Strong**, General Motors Corp.  
**S. W. Vass**, Nova Machine Products  
**C. B. Wackrow**, MNP Corp.  
**W. K. Wilcox**, Consultant  
**C. B. Williamson**, Fastenal Co.  
**C. J. Wilson**, Industrial Fasteners Institute  
**R. B. Wright**, Wright Tool Co.  
**J. G. Zeratsky**, National Rivet and Manufacturing Co.

### SUBCOMMITTEE 2 — EXTERNALLY DRIVEN FASTENERS

**S. W. Vass**, *Chair*, Nova Machine Products  
**R. L. Crane**, *Secretary*, The American Society of Mechanical Engineers  
**H. S. Brenner**, Almay Consultants  
**D. A. Clever**, Deere and Co.  
**A. P. Cockman**, Ford Motor Co.  
**B. A. Dusina**, Federal Screw Works  
**J. S. Foote**, Trade Association Management, Inc.  
**D. S. George**, Ford Motor Co.  
**J. Greenslade**, Greenslade and Co.  
**A. Herskovitz**, Consultant  
**M. W. Holubecki**, Electric Boat Corp.  
**J. Hubbard**, Rockford Fastener, Inc.

**J. Jennings**, *Corresponding Member*, Naval Surface Warfare Center  
**M. Keller**, Paracad Technology Co.  
**D. McCrindle**, Canadian Fasteners Institute  
**R. B. Meade**, R. Bruce Meade and Associates, LLC  
**J. A. Roley**, Caterpillar, Inc.  
**S. Savoji**, ITW Medalist  
**G. M. Simpson**, Semblex Corp.  
**W. R. Stevens**, Ramco  
**R. D. Strong**, General Motors Corp.  
**C. B. Wackrow**, MNP Corp.  
**W. K. Wilcox**, Consultant  
**C. B. Williamson**, Fastenal Co.  
**C. J. Wilson**, Industrial Fasteners Institute

## CORRESPONDENCE WITH B18 COMMITTEE

**General.** ASME Standards are developed and maintained with the intent to represent the consensus of concerned interests. As such, users of this Standard may interact with the Committee by requesting interpretations, proposing revisions, and attending committee meetings. Correspondence should be addressed to:

Secretary, B18 Standards Committee  
The American Society of Mechanical Engineers  
Three Park Avenue  
New York, New York 10016-5990

**Proposing Revisions.** Revisions are made periodically to the standard to incorporate changes that appear necessary or desirable, as demonstrated by the experience gained from the application of the standard. Approved revisions will be published periodically.

The Committee welcomes proposals for revisions to this Standard. Such proposals should be as specific as possible: citing the paragraph number(s), the proposed wording, and a detailed description of the reasons for the proposal, including any pertinent documentation.

**Interpretations.** On request, the B18 Committee will render an interpretation of any requirement of the standard. Interpretations can only be rendered in response to a written request sent to the Secretary of the B18 Standards Committee.

The request for interpretation should be clear and unambiguous. It is further recommended that the inquirer submit his/her request in the following format:

Subject: Cite the applicable paragraph number(s) and the topic of the inquiry.  
Edition: Cite the applicable edition of the standard for which the interpretation is being requested.  
Question: Phrase the question as a request for an interpretation of a specific requirement suitable for general understanding and use, not as a request for an approval of a proprietary design or situation. The inquirer may also include any plans or drawings that are necessary to explain the question; however, they should not contain proprietary names or information.

Requests which are not in this format will be rewritten by the Committee prior to being answered, which may inadvertently change the intent of the original request.

ASME procedures provide for reconsideration of any interpretation when or if additional information that might affect an interpretation is available. Further, persons aggrieved by an interpretation may appeal to the cognizant ASME Committee or Subcommittee. ASME does not "approve," "certify," "rate," or "endorse" any item, construction, proprietary device, or activity.

**Attending Committee Meetings.** The B18 Standards Committee regularly holds meetings, which are open to the public. Persons wishing to attend any meeting should contact the Secretary of the B18 Standards Committee.





# FASTENERS FOR USE IN STRUCTURAL APPLICATIONS

## 1 INTRODUCTORY NOTES

### 1.1 Scope

**1.1.1** This Standard covers the complete general and dimensional data for five products in the inch series recognized as American National Standard. These five structural products include:

- (a) Heavy Hex Structural Bolts: ASTM A 325 or ASTM A 490
- (b) Heavy Hex Nuts: ASTM A 563
- (c) Hardened Steel Washers; Circular, Circular Clipped or Beveled: ASTM F 436
- (d) Compressible Washer-Type Direct Tension Indicators: ASTM F 959
- (e) Twist-Off-Type Tension Control Structural Bolts: Heavy Hex and Round: ASTM F 1852

**1.1.2** The inclusion of dimensional data in this Standard is not intended to imply that all products described herein are stock production sizes. Consumers should consult with suppliers concerning lists of available stock production sizes.

### 1.2 Dimensions

All dimensions in this Standard are in inches, unless stated otherwise, and apply to unplated or uncoated product. When plating or coating is specified, the finished product dimensions shall be as agreed upon between supplier and purchaser. Symbols specifying geometric characteristics are in accord with ASME Y14.5M.

### 1.3 Options

Options, where specified, shall be at the discretion of the supplier, unless otherwise agreed upon by the purchaser with the manufacturer or distributor.

### 1.4 Terminology

For definitions of terms relating to fasteners or component features used in this Standard, refer to ASME B18.12.

### 1.5 Related Standards

Dimensional standards for other fasteners used in construction are published by ASME under separate covers such as, B18.2.1 and B18.2.2.

Standards for chemical and mechanical requirements for structural bolts are included in ASTM A 325, ASTM A 490, and ASTM F 1852. Heavy hex nuts are included in ASTM A 563. Hardened steel washers are included in

ASTM F 436. Compressible-washer-type direct tension indicators are included in ASTM F 959.

### 1.6 References

Unless otherwise specified, the referenced standard shall be the most recent issue.

- ASME B1.1, Unified Inch Screw Threads (UN and UNR Thread Form)
- ASME B1.2, Gages and Gaging for Unified Inch Screw Threads
- ASME B1.3M, Screw Thread Gaging Systems for Dimensional Acceptability — Inch and Metric Screw Threads (UN, UNR, UNJ, M, and MJ)
- ASME B18.2.1, Square and Hex Bolts and Screws (Inch Series)
- ASME B18.2.2, Square and Hex Nuts (Inch Series)
- ASME B18.12, Glossary of Terms for Mechanical Fasteners
- ASME B18.18.1M, Inspection and Quality Assurance for General Purpose Fasteners
- ASME B18.18.2M, Inspection and Quality Assurance for High-Volume Machine Assembly
- ASME B18.18.3M, Inspection and Quality Assurance for Special Purpose Fasteners
- ASME B18.18.4M, Inspection and Quality Assurance for Fasteners for Highly Specialized Engineered Applications
- ASME B18.24, Part Identifying Number (PIN) Code System for B18 Fasteners
- ASME Y14.5M, Dimensioning and Tolerancing
- Publisher: The American Society of Mechanical Engineers (ASME), Three Park Avenue, New York, NY 10016-5990; Order Department: 22 Law Drive, P.O. Box 2300, Fairfield, NJ 07007-2300
- ASTM A 153, Zinc Coating (Hot-Dip) on Iron and Steel Hardware
- ASTM A 325, Structural Bolts, Steel, Heat Treated, 120/105 ksi Minimum Tensile Strength
- ASTM A 490, Structural Bolts, Alloy Steel, Heat Treated, 150 ksi Minimum Tensile Strength
- ASTM A 563, Carbon and Alloy Steel Nuts
- ASTM B 695, Coatings of Zinc Mechanically Deposited on Iron and Steel
- ASTM F 436, Hardened Steel Washers
- ASTM F 788/F 788M, Surface Discontinuities of Bolts, Screws, and Studs
- ASTM F 812/F 812M, Surface Discontinuities of Nuts

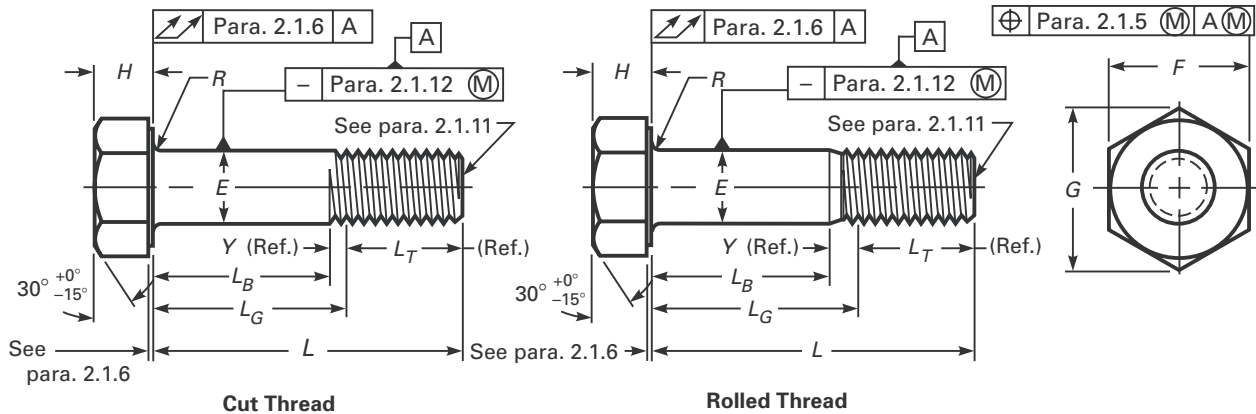

**Table 1 Dimensions of Heavy Hex Structural Bolts**

Nominal Size or Basic Product Diameter [Note (1)]	Body Diameter, E [Note (2)]		Width Across Flats, F [Note (3)]		Width Across Corners, G		Head Height, H [Note (4)]			Radius of Fillet, R		Thread Length, L <sub>T</sub> [Note (5)]	Transition Thread Length, Y [Note (5)]	Total Runout of Bearing Surface FIM [Note (6)]		
	Max.	Min.	Nominal	Max.	Min.	Max.	Min.	Nominal	Max.	Min.	Max.	Min.	Ref.	Ref.	Max.	
1/2	0.500	0.515	0.482	7/8	0.875	0.850	1.010	0.969	5/16	0.323	0.302	0.031	0.009	1.00	0.19	0.016
5/8	0.625	0.642	0.605	1 1/16	1.062	1.031	1.227	1.175	25/64	0.403	0.378	0.062	0.021	1.25	0.22	0.019
3/4	0.750	0.768	0.729	1 1/4	1.250	1.212	1.443	1.383	15/32	0.483	0.455	0.062	0.021	1.38	0.25	0.022
7/8	0.875	0.895	0.852	1 7/16	1.438	1.394	1.660	1.589	35/64	0.563	0.531	0.062	0.031	1.50	0.28	0.025
1	1.000	1.022	0.976	1 5/8	1.625	1.575	1.876	1.796	39/64	0.627	0.591	0.093	0.062	1.75	0.31	0.028
1 1/8	1.125	1.149	1.098	1 13/16	1.812	1.756	2.093	2.002	11/16	0.718	0.658	0.093	0.062	2.00	0.34	0.032
1 1/4	1.250	1.277	1.223	2	2.000	1.938	2.309	2.209	25/32	0.813	0.749	0.093	0.062	2.00	0.38	0.035
1 3/8	1.375	1.404	1.345	2 3/16	2.188	2.119	2.526	2.416	27/32	0.878	0.810	0.093	0.062	2.25	0.44	0.038
1 1/2	1.500	1.531	1.470	2 3/8	2.375	2.300	2.742	2.622	15/16	0.974	0.902	0.093	0.062	2.25	0.44	0.041

GENERAL NOTE: See additional requirements in section 2.

NOTES:

- (1) See para. 2.4.1.
- (2) See para. 2.1.7.
- (3) See paras. 2.1.2 and 2.1.3.
- (4) See para. 2.1.4.
- (5) See para. 2.1.10.2.
- (6) See para. 2.1.6.

ASTM F 959, Compressible-Washer-Type Direct Tension Indicators for Use With Structural Fasteners

ASTM F 1852, Twist Off Type Tension Control Structural Bolt/Nut/Washer Assemblies, Steel, Heat Treated, 120/105 ksi Minimum Tensile Strength

ASTM F 2329, Zinc Coating, Hot-Dip, Requirements for Application to Carbon and Alloy Steel Bolts, Screws, Washers, Nuts, and Special Threaded Fasteners

Publisher: ASTM International (ASTM), 100 Barr Harbor Drive, P.O. Box C700, West Conshohocken, PA 19428-2959

**1.7 Part Identifying Number**

For a part identifying number (PIN), refer to ASME B18.24.

**2 HEAVY HEX STRUCTURAL BOLTS: ASTM A 325 OR ASTM A 490**

**2.1 Dimensions**

Bolts shall conform to the dimensions given in Table 1. Formulas for heavy hex structural bolts are given in the Appendix of ASME B18.2.1.

**2.1.1 Top of Head.** Top of head shall be full form and chamfered or rounded with the diameter of chamfer circle, or start of rounding being equal to the maximum width across flats within a tolerance of -15%.

**2.1.2 Width Across Flats.** The width across flats of heads shall be the distance measured perpendicular to

the axis of product, overall between two opposite sides of the head.

**2.1.3 Head Taper.** The maximum width across flats shall not be exceeded. No transverse section through the head between 25% and 75% of actual head height, as measured from the bearing surface, shall be less than the minimum width across flats.

**2.1.4 Head Height.** The head height shall be that overall distance measured parallel to the axis of the product from the top of the head to the bearing surface and shall include the thickness of the washer face. Raised grade and manufacturer's identification are excluded from head height.

**2.1.5 True Position of Head.** The axis of the head shall be located at true position with respect to the axis of the body (determined over a distance under the head equal to one diameter) within a tolerance zone having a diameter equivalent to 6% of the maximum width across flats at maximum material condition.

**2.1.6 Bearing Surface.** Bearing surface shall be flat and washer faced. Diameter of washer face shall be equal to the maximum width across flats within a tolerance of  $-10\%$ .

Thickness of the washer face shall be not less than 0.015 in., nor greater than 0.025 in. for bolt sizes  $\frac{3}{4}$  in. and smaller, and not less than 0.015 in. nor greater than 0.035 in. for sizes larger than  $\frac{3}{4}$  in.

The plane of the bearing surface shall be perpendicular to the axis of the body within the FIM limits specified for total runout. Measurement of FIM shall extend as close to the periphery of the bearing surface as possible while the bolt is being held in a collet or other gripping device at a distance of one bolt diameter from the underside of the head.

**2.1.7 Body Diameter.** The body diameter limits are shown in Table 1. Any swell or fin under the head or any die seam on the body shall not exceed the basic bolt diameter by the following:

- (a) 0.030 in. for sizes  $\frac{1}{2}$  in.
- (b) 0.050 in. for sizes  $\frac{5}{8}$  in. and  $\frac{3}{4}$  in.
- (c) 0.060 in. for sizes over  $\frac{3}{4}$  in. through  $1\frac{1}{4}$  in.
- (d) 0.090 in. for sizes over  $1\frac{1}{4}$  in.

**2.1.8 Bolt Length.** The bolt length shall be the distance measured parallel to the axis of the product from the bearing surface of the head to the extreme end of the bolt including point. Bolts are normally furnished in  $\frac{1}{4}$  in. length increments.

**2.1.9 Length Tolerance.** Bolt length tolerances shall be as tabulated below:

Nominal Bolt Size, in.	Nominal Bolt Length Tolerance	
	Through 6 in.	Over 6 in.
$\frac{1}{2}$	-0.12	-0.19
$\frac{5}{8}$	-0.12	-0.25
$\frac{3}{4}$ through 1	-0.19	-0.25
$1\frac{1}{8}$ through $1\frac{1}{2}$	-0.25	-0.25

**2.1.10 Threads.** Threads shall be cut or rolled in accordance with ASME B1.1 Unified Coarse, Class 2A. When specified, 8 thread series may be used on bolts over 1 in. in diameter. Structural bolts shall not be undersized to accommodate heavy coatings. Threads which have been hot-dipped or mechanically zinc coated shall meet the requirements specified in ASTM A 325.

**2.1.10.1 Thread Acceptability.** Unless otherwise specified by the purchaser, gaging for screw thread dimensional acceptability shall be in accordance with Gaging System 21 as specified in ASME B1.3M.

**2.1.10.2 Thread Length.** The length of thread on bolts shall be controlled by the grip gaging length,  $L_G$  max., and the body length,  $L_B$  min.

Grip gaging length,  $L_G$ , is the distance measured parallel to the axis of bolt from the underhead bearing surface to the face of a noncounterbored or noncountersunk standard GO thread ring gage, assembled by hand as far as the thread will permit. It shall be used as the criterion for inspection. The maximum grip gaging length, as calculated and rounded to two decimal places for any bolt not threaded full length, shall be equal to the nominal bolt length minus the thread length ( $L_G$  max. =  $L$  nom. -  $L_T$ ). For bolts that are threaded full length,  $L_G$  max. defines the unthreaded length under the head and shall not exceed the length of 2.5 times the thread pitch for sizes up to and including 1 in., and 3.5 times the thread pitch for sizes larger than 1 in.  $L_G$  max. represents the minimum design grip length of the bolt and may be used for determining thread availability when selecting bolt lengths even though usable threads may extend beyond this point, see Table 2.

Thread length,  $L_T$ , is a reference dimension, intended for calculation purposes only, which represents the distance from the extreme end of the bolt to the last complete (full form) thread.

Body length,  $L_B$ , is the distance measured parallel to the axis of bolt from the underhead bearing surface to the last scratch of thread, or to the top of the extrusion angle. It shall be used as a criterion for inspection. The minimum body length, as calculated and rounded to two decimal places, shall be equal to the maximum grip gaging length minus the transition thread length ( $L_T$  min. =  $L_G$  max. -  $Y$ ). Bolts of nominal lengths which have a calculated  $L_B$  min. length equal to or shorter than 2.5 times the thread pitch for sizes 1 in. and smaller,

**Table 2 Maximum Grip Gaging Lengths and Minimum Body Lengths for Heavy Hex Structural Bolts**

Nominal Diameter and Thread Pitch <i>L</i>	$\frac{1}{2}$ -13		$\frac{5}{8}$ -11		$\frac{3}{4}$ -10		$\frac{7}{8}$ -9		1-8		$1\frac{1}{8}$ -7		$1\frac{1}{4}$ -7		$1\frac{3}{8}$ -6		$1\frac{1}{2}$ -6	
	<i>L<sub>G</sub></i>	<i>L<sub>B</sub></i>	<i>L<sub>G</sub></i>	<i>L<sub>B</sub></i>	<i>L<sub>G</sub></i>	<i>L<sub>B</sub></i>	<i>L<sub>G</sub></i>	<i>L<sub>B</sub></i>	<i>L<sub>G</sub></i>	<i>L<sub>B</sub></i>	<i>L<sub>G</sub></i>	<i>L<sub>B</sub></i>	<i>L<sub>G</sub></i>	<i>L<sub>B</sub></i>	<i>L<sub>G</sub></i>	<i>L<sub>B</sub></i>	<i>L<sub>G</sub></i>	<i>L<sub>B</sub></i>
	Max.	Min.	Max.	Min.	Max.	Min.	Max.	Min.	Max.	Min.	Max.	Min.	Max.	Min.	Max.	Min.	Max.	Min.
1½	0.50	0.31	...	...	...	...	...	...	...	...	...	...	...	...	...	...	...	...
1¾	0.75	0.56	0.50	0.28	...	...	...	...	...	...	...	...	...	...	...	...	...	...
2	1.00	0.81	0.75	0.53	0.62	0.38	...	...	...	...	...	...	...	...	...	...	...	...
2¼	1.25	1.06	1.00	0.78	0.88	0.62	0.75	0.47	...	...	...	...	...	...	...	...	...	...
2½	1.50	1.31	1.25	1.03	1.12	0.88	1.00	0.72	0.75	0.44	...	...	...	...	...	...	...	...
2¾	1.75	1.56	1.50	1.28	1.38	1.12	1.25	0.97	1.00	0.69	...	...	...	...	...	...	...	...
3	2.00	1.81	1.75	1.53	1.62	1.38	1.50	1.22	1.25	0.94	1.00	0.66	1.00	0.62	...	...	...	...
3¼	2.25	2.06	2.00	1.78	1.88	1.62	1.75	1.47	1.50	1.19	1.25	0.91	1.25	0.88	...	...	...	...
3½	2.50	2.31	2.25	2.03	2.12	1.88	2.00	1.72	1.75	1.44	1.50	1.16	1.50	1.12	1.25	0.81	...	...
3¾	2.75	2.56	2.50	2.28	2.38	2.12	2.25	1.97	2.00	1.69	1.75	1.41	1.75	1.38	1.50	1.06	...	...
4	3.00	2.81	2.75	2.53	2.62	2.38	2.50	2.22	2.25	1.94	2.00	1.66	2.00	1.62	1.75	1.31	1.75	1.31
4¼	3.25	3.06	3.00	2.78	2.88	2.62	2.75	2.47	2.50	2.19	2.25	1.91	2.25	1.88	2.00	1.56	2.00	1.56
4½	3.50	3.31	3.25	3.03	3.12	2.88	3.00	2.72	2.75	2.44	2.50	2.16	2.50	2.12	2.25	1.81	2.25	1.81
4¾	3.75	3.56	3.50	3.28	3.38	3.12	3.25	2.97	3.00	2.69	2.75	2.41	2.75	2.38	2.50	2.06	2.50	2.06
5	4.00	3.81	3.75	3.53	3.62	3.38	3.50	3.22	3.25	2.94	3.00	2.66	3.00	2.62	2.75	2.31	2.75	2.31
5¼	4.25	4.06	4.00	3.78	3.88	3.62	3.75	3.47	3.50	3.19	3.25	2.91	3.25	2.88	3.00	2.56	3.00	2.56
5½	4.50	4.31	4.25	4.03	4.12	3.88	4.00	3.72	3.75	3.44	3.50	3.16	3.50	3.12	3.25	2.81	3.25	2.81
5¾	4.75	4.56	4.50	4.28	4.38	4.12	4.25	3.97	4.00	3.69	3.75	3.41	3.75	3.38	3.50	3.06	3.50	3.06
6	5.00	4.81	4.75	4.53	4.62	4.38	4.50	4.22	4.25	3.94	4.00	3.66	4.00	3.62	3.75	3.31	3.75	3.31
6¼	5.25	5.06	5.00	4.78	4.88	4.62	4.75	4.47	4.50	4.19	4.25	3.91	4.25	3.88	4.00	3.56	4.00	3.56
6½	5.50	5.31	5.25	5.03	5.12	4.88	5.00	4.72	4.75	4.44	4.50	4.16	4.50	4.12	4.25	3.81	4.25	3.81
6¾	5.75	5.56	5.50	5.28	5.38	5.12	5.25	4.97	5.00	4.69	4.75	4.41	4.75	4.38	4.50	4.06	4.50	4.06
7	6.00	5.81	5.75	5.53	5.62	5.38	5.50	5.22	5.25	4.94	5.00	4.66	5.00	4.62	4.75	4.31	4.75	4.31
7¼	6.25	6.06	6.00	5.78	5.88	5.62	5.75	5.47	5.50	5.19	5.25	4.91	5.25	4.88	5.00	4.56	5.00	4.56
7½	6.50	6.31	6.25	6.03	6.12	5.88	6.00	5.72	5.75	5.44	5.50	5.16	5.50	5.12	5.25	4.81	5.25	4.81
7¾	6.75	6.56	6.50	6.28	6.38	6.12	6.25	5.97	6.00	5.69	5.75	5.41	5.75	5.38	5.50	5.06	5.50	5.06
8	7.00	6.81	6.75	6.53	6.62	6.38	6.50	6.22	6.25	5.94	6.00	5.66	6.00	5.62	5.75	5.31	5.75	5.31
8¼	7.25	7.06	7.00	6.78	6.88	6.62	6.75	6.47	6.50	6.19	6.25	5.91	6.25	5.88	6.00	5.56	6.00	5.56
8½	7.50	7.31	7.25	7.03	7.12	6.88	7.00	6.72	6.75	6.44	6.50	6.16	6.50	6.12	6.25	5.81	6.25	5.81
8¾	7.75	7.56	7.50	7.28	7.38	7.12	7.25	6.97	7.00	6.69	6.75	6.41	6.75	6.38	6.50	6.06	6.50	6.06
9	8.00	7.81	7.75	7.53	7.62	7.38	7.50	7.22	7.25	6.94	7.00	6.66	7.00	6.62	6.75	6.31	6.75	6.31
9¼	8.25	8.06	8.00	7.78	7.88	7.62	7.75	7.47	7.50	7.19	7.25	6.91	7.25	6.88	7.00	6.56	7.00	6.56
9½	8.50	8.31	8.25	8.03	8.12	7.88	8.00	7.72	7.75	7.44	7.50	7.16	7.50	7.12	7.25	6.81	7.25	6.81
9¾	8.75	8.56	8.50	8.28	8.38	8.12	8.25	7.97	8.00	7.69	7.75	7.41	7.75	7.38	7.50	7.06	7.50	7.06
10	9.00	8.81	8.75	8.53	8.62	8.38	8.50	8.22	8.25	7.94	8.00	7.66	8.00	7.62	7.75	7.31	7.75	7.31

and 3.5 times the thread pitch for sizes larger than 1 in., shall be threaded for full length, see Table 2.

Transition thread length,  $Y$ , is a reference dimension, intended for calculation purposes only, which represents the length of incomplete threads and tolerance on grip gaging length.

**2.1.10.3 Incomplete Thread Diameter.** The major diameter of incomplete thread shall not exceed the actual major diameter of the full form thread.

**2.1.11 Point.** Point shall be chamfered or rounded at the manufacturer's option from approximately 0.016 in. below the minor diameter of the thread. The first full formed thread at major diameter is located a distance no greater than 2 times the pitch measured from the end of the bolt. This distance is to be determined by measuring how far the point enters into a cylindrical NOT GO major diameter ring gage (reference Gage, ASME B1.2).

**2.1.12 Straightness.** Shanks of bolts shall be straight within the following limits at MMC:

(a) for bolts with nominal lengths to and including 12 in., the maximum camber shall be 0.006 in. per inch (0.006 L) of bolt length.

(b) for bolts with nominal lengths over 12 in. to and including 24 in., the maximum camber shall be 0.008 in. per inch (0.008 L) of length.

A suggested gage and gaging procedure for checking bolt straightness is given in ASME B18.2.1 Appendix II.

## 2.2 Materials and Processing

Chemical and mechanical properties of steel bolts shall conform to ASTM A 325 or ASTM A 490.

## 2.3 Finish

Structural fasteners shall be plain finish unless a zinc coating for all but A 490 bolts is specified. ASTM A 490 forbids any bolt from having a metallic coating. ASTM A 325 structural bolts may be coated with zinc in accordance with ASTM F 2329 or ASTM B 695 Class 50, Type I (ASTM A 153 Class C may be used as an option to ASTM F 2329 until the current references in ASTM F 16 Standards have been revised).

## 2.4 Designation

Heavy hex structural bolts shall be designated by the following data in the sequence shown: product name, specification, nominal size (fractional or decimal equivalent), threads per inch, product length (fractional or two-decimal place equivalent), material (including specification and type where necessary), and protective finish (if required).

EXAMPLE: Heavy Hex Structural Bolt, ASME B18.2.6,  $\frac{3}{4}$  - 10  $\times$  2 $\frac{1}{4}$ , Type 1, Hot-Dip Zinc Coated, ASTM F 2329

**2.4.1 Nominal Size.** Where specifying nominal size in decimals, zeros preceding the decimal shall be used and the fourth decimal place shall be omitted.

EXAMPLE: Heavy Hex Structural Bolt, ASME B18.2.6, 0.750 - 10  $\times$  2.25, Type 1, Hot-Dip Zinc Coated, ASTM F 2329

## 2.5 Identification Symbols

Identification marking symbols on the tops of heads for bolt sizes  $\frac{5}{8}$  in., and smaller shall project not less than 0.005 in. above the surface nor more than 0.015 in. over the specified maximum head height. Bolt sizes larger than  $\frac{5}{8}$  in. shall project not less than the equivalent in inches of 0.0075 times the basic bolt diameter above the surface nor more than 0.030 in. over the specified maximum head height.

**2.5.1 Grade Symbols.** Each bolt shall be marked in accordance with the requirements of the applicable specification, ASTM A 325 or ASTM A 490.

**2.5.2 Source Symbols.** Each bolt shall be marked to identify the source (manufacturer or private label distributor) accepting the responsibility for conformance to this and other applicable specifications.

## 2.6 Workmanship

Bolts shall be free from burrs, seams, laps, loose scale, irregular surfaces, and any defects affecting serviceability. When control of surface discontinuities is required, the purchaser shall specify conformance to ASTM F 788/F 788M.

## 2.7 Quality Assurance

Unless otherwise specified, products shall be furnished in accordance with ASME B18.18.1M and ASME B18.18.2M.

**2.7.1 Designated Characteristics.** The designated characteristics defined in the table below shall be inspected in accordance with ASME B18.18.2M. For non-designated characteristics, the provisions of ASME B18.18.1M shall apply.

Characteristic	Inspection Level
Threads	C
Width across corners	C
Head height	C
Grip length	C
Visual	C

Should a nondesignated dimension be determined to be outside its specified limits, it shall be deemed conforming to this standard if the user, who is the installer, accepts the dimension based on fit, form, and function considerations. Where verifiable in-process inspection is used in accordance with ASME B18.18.3M or ASME B18.18.4M, the final inspection level sample sizes of those respective standards shall apply.

## 3 HEAVY HEX NUTS: ASTM A 563

### 3.1 Dimensions

Nuts shall conform to the dimensions given in Table 3. Heavy hex nut formulas for thickness, width across flats,

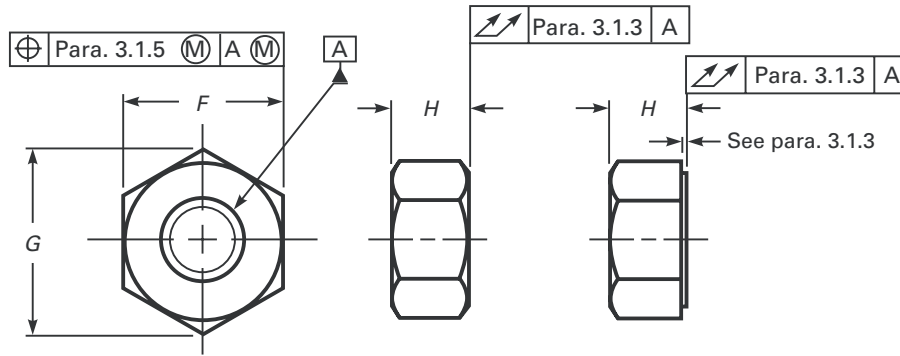

**Table 3 Dimensions of Heavy Hex Nuts for Use With Structural Bolts**

Nominal Size or Basic Major Diameter of Thread [Note (1)]		Width Across Flats, <i>F</i> [Note (2)]			Width Across Corners, <i>G</i> [Note (3)]		Thickness, <i>H</i> [Note (4)]			Total Runout of Bearing Face <i>FIM</i> , Heavy Hex Nuts, Specified Proof Load [Note (5)]	
		Nominal	Max.	Min.	Max.	Min.	Nominal	Max.	Min.	Under	150,000
										150,000 psi	psi and Greater
$\frac{1}{2}$	0.500	$\frac{7}{8}$	0.875	0.850	1.010	0.969	$\frac{31}{64}$	0.504	0.464	0.023	0.016
$\frac{5}{8}$	0.625	$1\frac{1}{16}$	1.062	1.031	1.227	1.175	$\frac{39}{64}$	0.631	0.587	0.025	0.018
$\frac{3}{4}$	0.750	$1\frac{1}{4}$	1.250	1.212	1.443	1.382	$\frac{47}{64}$	0.758	0.710	0.027	0.020
$\frac{7}{8}$	0.875	$1\frac{7}{16}$	1.438	1.394	1.660	1.589	$\frac{55}{64}$	0.885	0.833	0.029	0.022
1	1.000	$1\frac{5}{8}$	1.625	1.575	1.876	1.796	$\frac{63}{64}$	1.012	0.956	0.031	0.024
$1\frac{1}{8}$	1.125	$1\frac{13}{16}$	1.812	1.756	2.093	2.002	$1\frac{7}{64}$	1.139	1.079	0.033	0.027
$1\frac{1}{4}$	1.250	2	2.000	1.938	2.309	2.209	$1\frac{7}{32}$	1.215	1.187	0.035	0.030
$1\frac{3}{8}$	1.375	$2\frac{3}{16}$	2.188	2.119	2.526	2.416	$1\frac{11}{32}$	1.378	1.310	0.038	0.033
$1\frac{1}{2}$	1.500	$2\frac{3}{8}$	2.375	2.300	2.742	2.622	$1\frac{15}{32}$	1.505	1.433	0.041	0.036

GENERAL NOTE: See additional requirements in section 3. Complete table included in ASME B18.2.2.

NOTES:

- (1) See para. 2.4.1.
- (2) See para. 3.1.1.
- (3) See para. 3.1.4.
- (4) See para. 3.1.2.
- (5) See para. 3.1.3.

and width across corners are given in Appendix II of ASME B18.2.2.

**3.1.1 Width Across Flats.** The width across flats of heavy hex nuts shall be the overall distance measured, perpendicular to the axis of the nut, between two opposite sides of the nut in accordance with Table 3. For milled-from-bar hex nuts, the nominal bar size used shall be the closest commercially available size to the specified basic width across flats of the nut.

Maximum width across flats shall not be exceeded (except as stated in the previous paragraph). No transverse section through the nut between 25% and 75% of the actual nut thickness, as measured from the bearing surface, shall be less than the minimum width across flats.

**3.1.2 Nut Thickness.** The nut thickness shall be the overall distance measured parallel to the axis of the nut, from the top of the nut to the bearing surface, and shall include the thickness of the washer face where provided.

**3.1.3 Tops and Bearing Surfaces.** Nuts may be double chamfered or have washer faced bearing surface and chamfered top.

The diameter of chamfer circle on double chamfered nuts and diameter of washer face shall be within the limits of the maximum width across flats and 95% of the minimum width across flats.

The tops of washer faced nuts shall be flat and the diameter of chamfer circle shall be equal to the maximum width across flats within a tolerance of  $-15\%$ . The length of chamfer at hex corners shall be 5% to 15% of

the basic thread diameter. The surface of chamfer may be slightly convex or rounded.

Bearing surfaces shall be flat and, unless otherwise specified, shall be perpendicular to the axis of the threaded hole within the total runout (FIM) tabulated for the respective nut size, type, and strength level.

**3.1.4 Corner Fill.** A rounding or lack of fill at junction of hex corners with chamfer shall be permissible, provided the width across corners is within specified limits at and beyond a distance equal to 17.5% of the basic thread diameter from the chamfered faces.

**3.1.5 Position of Hexagon to Tapped Hole.** At maximum material condition, the axis of nut body shall be located at true position with respect to the axis of the thread pitch diameter within a tolerance zone having a diameter equivalent to 4% of the maximum width across flats for 1½ in. nominal size nuts or smaller.

**3.1.6 Countersink.** Tapped hole shall be countersunk on the bearing face or faces. The maximum countersink diameter shall be 1.08 times the thread basic (nominal) major diameter. No part of the threaded portion shall project beyond the bearing surface.

**3.1.7 Threads.** Threads shall be UNC or 8 UN Class 2B in accordance with ASME B1.1. When specified, 8 thread series may be used on nuts over 1 in. in diameter.

**3.1.7.1 Thread Gaging.** Unless otherwise specified by the purchaser, gaging for screw thread dimensional acceptability shall be in accordance with Gaging System 21 as specified in ASME B1.3M.

**3.1.7.2 Overtapping.** When nuts are zinc coated, they shall be overtapped after coating in accordance with the provisions of ASTM A 563.

## 3.2 Materials

Chemical and mechanical properties of heavy hex nuts shall conform to ASTM A 563.

## 3.3 Finish

Unless otherwise specified, nuts shall be supplied with a plain (as-processed) finish, unplated or uncoated. If zinc coatings are required, they shall be in accordance with ASTM A 563.

## 3.4 Designation

Nuts shall be designated by the following data in the sequence shown: product name, specification, nominal size (fraction or decimal), threads per inch, material (including specification where necessary), and protective finish (if required).

EXAMPLE: Heavy Hex Nut ASME B18.2.6, ½ - 13, ASTM A 563 Grade C, Plain Finish

## 3.5 Identification Symbols

**3.5.1 Grade Symbols.** Each nut shall be marked in accordance with the requirements of ASTM A 563.

**3.5.2 Source Symbols.** Each nut shall be marked to identify the source (manufacturer or private label distributor) accepting the responsibility for conformance to this and other applicable specifications.

## 3.6 Workmanship

Nuts shall be free from burrs, seams, laps, loose scale, irregular surfaces, and any defects affecting their serviceability. When control of surface discontinuities is required, the purchaser shall specify conformance to ASTM F 812/F 812M.

## 3.7 Quality Assurance

Unless otherwise specified, products shall be furnished in accordance with ASME B18.18.1M and ASME B18.18.2M as noted in para. 3.7.1.

**3.7.1 Designated Characteristics.** The designated characteristics defined in the following table shall be inspected in accordance with ASME B18.18.2M.

Designated Characteristic	Inspection Level
Width across corners	C
Thickness	B
Visual	C

For nondesignated characteristics, the provisions of ASME B18.18.1M shall apply. Should a nondesignated dimension be determined to be outside its specified limits, it shall be deemed conforming to this standard if the user, who is the installer, accepts the dimension based on fit, form, and function considerations. Where verifiable in-process inspection is used in accordance with ASME B18.18.3M or ASME B18.18.4M, the final inspection level sample sizes of those respective standards shall apply.

## 4 HARDENED STEEL WASHERS

### 4.1 Circular or Circular Clipped Washers

**4.1.1 Dimensions.** All circular and circular clipped washers shall conform to the dimensions given in Table 4.

**4.1.2 Tolerances.** Washer inside diameter, outside diameter, thickness, and edge distance shall be in accordance with Table 4. The deviation from flatness shall not exceed 0.010 in. as the maximum deviation from a straight edge placed on the cut side. Circular runout of the outside diameter with respect to the hole shall not exceed 0.030 FIM. Burrs shall not project above immediately adjacent washer surface more than 0.010 in.

**4.1.3 Finish.** Unless otherwise specified, washers shall be supplied with a plain (as-processed) finish. If



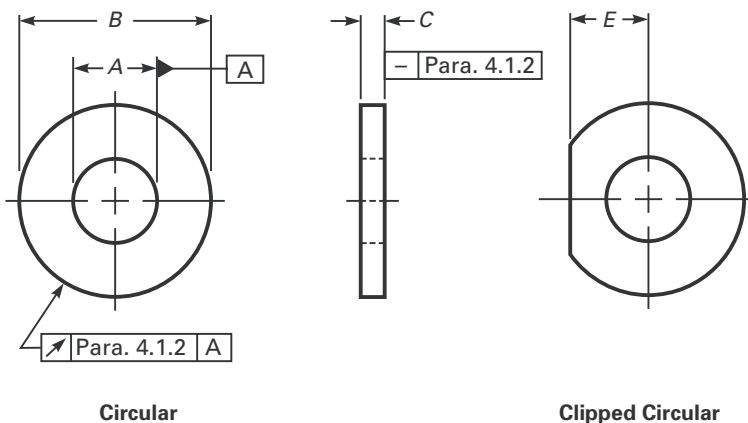

**Table 4 Dimensions for Hardened Steel Circular and Circular Clipped Washers**

Basic Size or Nominal Washer Size, in. [Note (1)]	Inside Diameter, A			Outside Diameter, B			Thickness, C		Nominal Edge Distance, E [Note (2)]
	Nominal	Tolerance		Nominal	Tolerance		Min.	Max.	
		Plus	Minus		Plus	Minus			
1/2	0.531	0.0313	0	1.063	0.0313	0.0313	0.097	0.177	0.438
5/8	0.688	0.0313	0	1.313	0.0313	0.0313	0.122	0.177	0.547
3/4	0.813	0.0313	0	1.469	0.0313	0.0313	0.122	0.177	0.656
7/8	0.938	0.0313	0	1.750	0.0313	0.0313	0.136	0.177	0.766
1	1.125	0.0313	0	2.000	0.0313	0.0313	0.136	0.177	0.875
1 1/8	1.250	0.0313	0	2.250	0.0313	0.0313	0.136	0.177	0.984
1 1/4	1.375	0.0313	0	2.500	0.0313	0.0313	0.136	0.177	1.094
1 3/8	1.500	0.0313	0	2.750	0.0313	0.0313	0.136	0.177	1.203
1 1/2	1.625	0.0313	0	3.000	0.0313	0.0313	0.136	0.177	1.313

**NOTES:**

- (1) Nominal washer sizes are intended for use with comparable nominal bolt diameters.
- (2) Clipped edge E shall not be closer than 0.875 times the nominal bolt diameter from the center of the washer.

zinc coatings are required, they shall be in accordance with ASTM F 436.

**4.1.4 Materials and Mechanical Properties.** Materials and properties shall conform to the requirements established by ASTM F 436.

**4.1.5 Workmanship.** Washers shall be free from burrs, seams, laps, loose scale, irregular surfaces, and any defects affecting serviceability.

**4.1.6 Designation.** Washers shall be designated by the following data in the sequence shown: product name, specification, nominal size (fraction or decimal), material specification, and protective finish (if required).

EXAMPLE: Hardened Steel Circular Washer, ASME B18.2.6, 1 1/8, ASTM F 436, Hot-Dip Galvanized in Accordance with ASTM A 153 Class C.

**4.1.7 Identification Symbols.** Grade and source marking and symbols shall conform to the requirements

of ASTM F 436. The source marking is intended to identify the source accepting the responsibility for the conformance to this and other applicable specifications.

**4.1.8 Quality Assurance.** Unless otherwise specified, products shall be furnished in accordance with ASME B18.18.1M and ASME B18.18.2M, as noted in para. 4.1.8.1.

**4.1.8.1 Designated Characteristics.** The designated characteristics defined in the following table shall be inspected in accordance with ASME B18.18.2M.

Characteristic	Inspection Level
Inside diameter	B
Outside diameter	B
Visual	C

For nondesignated characteristics, the provisions of ASME B18.18.1M shall apply. Should a nondesignated dimension be determined to be outside its specified limits, it shall be deemed conforming to this standard if the

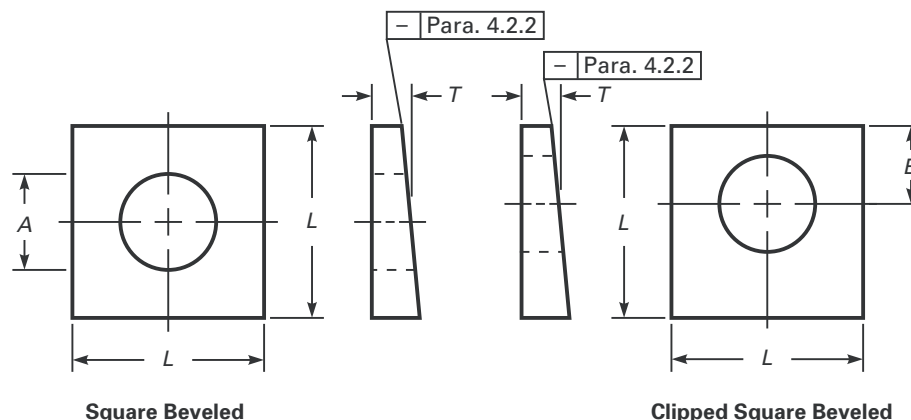

**Table 5 Dimensions of Hardened Beveled Washers With Slope or Taper in Thickness 1:6**

Nominal Washer Size [Note (1)]	Nominal	Tolerance		Minimum Side Length, $L$ [Note (2)]	Thickness, $T$	Nominal Edge Distance, $E$ [Note (3)]	
		Plus	Minus				
$\frac{1}{2}$	0.500	0.531	0.0313	0	1.750	0.313	0.438
$\frac{5}{8}$	0.625	0.688	0.0313	0	1.750	0.313	0.547
$\frac{3}{4}$	0.750	0.813	0.0313	0	1.750	0.313	0.656
$\frac{7}{8}$	0.875	0.938	0.0313	0	1.750	0.313	0.766
1	1.000	1.125	0.0313	0	1.750	0.313	0.875
$1\frac{1}{8}$	1.125	1.250	0.0313	0	2.250	0.313	0.984
$1\frac{1}{4}$	1.250	1.375	0.0313	0	2.250	0.313	1.094
$1\frac{3}{8}$	1.375	1.500	0.0313	0	2.250	0.313	1.203
$1\frac{1}{2}$	1.500	1.625	0.0313	0	2.250	0.313	1.313

**NOTES:**

- (1) Nominal washer sizes are intended for use with comparable nominal bolt diameters.
- (2) Nonclipped washers may be rectangular providing neither side dimension is less than  $L$ , and one side may be longer than that of the  $L$  min. included in the table.
- (3) Clipped edge  $E$  shall not be closer than 0.875 times the nominal bolt diameter from the center of the washer.

user, who is the installer, accepts the dimension based on fit, form, and function considerations. Where verifiable in-process inspection is used in accordance with ASME B18.18.3M or ASME B18.18.4M, the final inspection level sample sizes of those respective standards shall apply.

## 4.2 Square and Clipped Square Beveled Washers

**4.2.1 Dimensions.** All square beveled and clipped square beveled washers shall conform to the dimensions given in Table 5.

**4.2.2 Tolerances.** Tolerances for inside diameter for beveled washers shall be in accordance with Table 5. The flatness shall not exceed 0.010 in. as the maximum deviation from a straight edge placed on the cut side. Burrs shall not project above immediately adjacent washer surface more than 0.010 in. The slope or taper in thickness shall be 0.98:6 to 1.02:6.

**4.2.3 Finish.** Unless otherwise specified, washers shall be supplied with a plain (as-processed) finish. If zinc coatings are required, they shall be in accordance with ASTM F 436.

**4.2.4 Materials and Mechanical Properties.** Materials and properties shall conform to the requirements established by ASTM F 436.

**4.2.5 Workmanship.** Washers shall be free from burrs, seams, laps, loose scale, irregular surfaces, and any defects affecting serviceability.

**4.2.6 Designation.** Washers shall be designated by the following data in the sequence shown: product name, specification, nominal washer size (fraction or decimal), material specification, and protective finish (if required).

EXAMPLE: Square Beveled Washer, ASME B18.2.6,  $1\frac{1}{4}$ , ASTM F 436, Hot-Dip Galvanized in accordance with ASTM A 153 Class C.

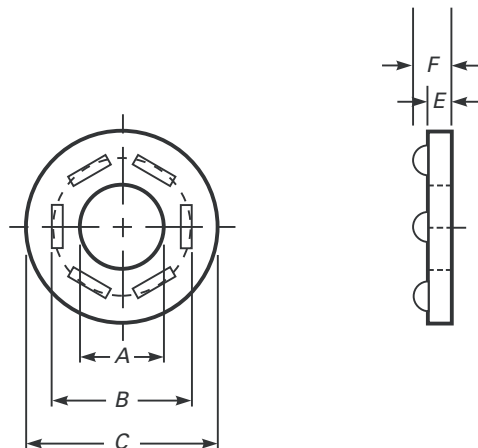

**Table 6 Dimensions for Compressible Washer-Type Direct Tension Indicators**

Direct Tension Indicator Size, in. [Note (1)]	All Types		Type A325				Type A490						
	Inside Diameter, in., A		Protrusion Tangential Diameter, in., B	Outside Diameter, in., C		Number of Protrusions (Equally Spaced)	Thickness, in.		Outside Diameter, in., C		Number of Protrusions (Equally Spaced)	Thickness, in.	
							Without Protrusion, E	With Protrusion, F				Without Protrusion, E	With Protrusion, F
	Min.	Max.	Max.	Min.	Max.	Min.	Max.	Min.	Max.	Min.	Max.		
1/2	0.523	0.527	0.788	1.167	1.187	4	0.104	0.180	1.355	1.375	5	0.104	0.180
5/8	0.654	0.658	0.956	1.355	1.375	4	0.126	0.220	1.605	1.625	5	0.126	0.220
3/4	0.786	0.790	1.125	1.605	1.625	5	0.126	0.230	1.730	1.750	6	0.142	0.240
7/8	0.917	0.921	1.294	1.855	1.875	5	0.142	0.240	1.980	2.000	6	0.158	0.260
1	1.048	1.052	1.463	1.980	2.000	6	0.158	0.270	2.230	2.250	7	0.158	0.270
1 1/8	1.179	1.183	1.631	2.230	2.250	6	0.158	0.270	2.480	2.500	7	0.158	0.280
1 1/4	1.311	1.315	1.800	2.480	2.500	7	0.158	0.270	2.730	2.750	8	0.158	0.280
1 3/8	1.442	1.446	1.969	2.730	2.750	7	0.158	0.270	2.980	3.000	8	0.158	0.280
1 1/2	1.573	1.577	2.138	2.980	3.000	8	0.158	0.270	3.230	3.250	9	0.158	0.280

GENERAL NOTE: Additional requirements are in section 5.

NOTE:

(1) Nominal direct tension indicator sizes are intended for use with fasteners of the same nominal diameter.

**4.2.7 Identification Symbols.** Grade and source marking and symbols shall conform to the requirements of ASTM F 436. The source marking is intended to identify the source accepting the responsibility for conformance to this and other applicable specifications.

**4.2.8 Quality Assurance.** Unless otherwise specified, products shall be furnished in accordance with ASME B18.18.1M and ASME B18.18.2M as noted in para. 4.2.9.

**4.2.9 Designated Characteristics.** The designated characteristics defined in the following table shall be inspected in accordance with ASME B18.18.2M.

Characteristic	Inspection Level
Inside diameter	B
Visual	C

For nondesignated characteristics, the provisions of ASME B18.18.1M shall apply. Should a nondesignated

dimension be determined to be outside its specified limits, it shall be deemed conforming to this standard if the user, who is the installer, accepts the dimension based on fit, form, and function considerations. Where verifiable in-process inspection is used in accordance with ASME B18.18.3M or ASME B18.18.4M, the final inspection level sample sizes of these respective standards shall apply.

## 5 COMPRESSIBLE WASHER-TYPE DIRECT TENSION INDICATORS

### 5.1 Dimensions

All washer-type direct tension indicators, Type A 325 and A 490, shall conform to the dimensions given in Table 6.

## 5.2 Finish

Unless otherwise specified, direct tension indicators shall be supplied with a plain (as-processed) finish, unplated, or uncoated. If a protective coating is required, it shall be in accordance with ASTM F 959.

## 5.3 Materials and Properties

Direct tension indicators shall conform to the requirements of ASTM F 959.

## 5.4 Workmanship

The workmanship shall be smooth and free of burrs, laps, seams, excess mill scale, and foreign material on bearing surfaces or in protrusions, or other defects which would make them unsuitable for intended application.

## 5.5 Designation

Compressible washer-type direct tension indicators shall be designated by the following data in the sequence shown: product name, specification, nominal size (fractional or decimal equivalent), Type (325 or 490), and finish (plain, zinc, or epoxy).

EXAMPLE: DTI, ASME B18.2.6,  $\frac{1}{2}$ , Type 325 per ASTM F 959, Plain Finish

## 5.6 Identification Symbols

Grade and source marking and symbols shall conform to the requirements of ASTM F 959.

**5.6.1 Lot Number.** Each direct tension indicator shall be marked with a lot number in accordance with ASTM F 959.

## 5.7 Quality Assurance

Unless otherwise specified, products shall be furnished in accordance with ASME B18.18.1M and ASME B18.18.2M as noted in para. 5.7.1.

**5.7.1 Designated Characteristics.** The designated characteristics defined in the following table, shall be inspected in accordance with ASME B18.18.2M.

Characteristic	Inspection Level
Inside diameter	B
Protrusion tangential diameter	B
Visual	C

For nondesignated characteristics, the provisions of ASME B18.18.1M shall apply. Should a nondesignated dimension be determined to be outside its specified limits, it shall be deemed conforming to this standard if the user, who is the installer, accepts the dimension based on fit, form, and function considerations. Where verifiable in-process inspection is used in accordance with ASME B18.18.3M or ASME B18.18.4M, the final inspection level sample sizes of these respective standards shall apply.

## 6 TWIST-OFF-TYPE TENSION CONTROL STRUCTURAL BOLTS: HEAVY HEX AND ROUND: ASTM F 1852

### 6.1 Dimensions

**6.1.1 Heavy Hex Heads.** Heavy hex head bolts shall conform to the dimensions included in Table 7.

**6.1.1.1 Top of Head.** The top of head shall be full formed and chamfered or rounded with the diameter of the chamfer circle or start of rounding being equal to the maximum width across flats within a tolerance of -15%.

**6.1.1.2 Width Across Flats.** The width across flats of heads shall be the distance measured perpendicular to the axis of the product, overall between two opposite sides of the head.

**6.1.1.3 Head Taper.** Maximum width across flats shall not be exceeded. No transverse section through the head between 25% and 75% of actual head height, as measured from the bearing surface, shall be less than the minimum width across flats.

**6.1.1.4 Head Height.** The head height shall be that overall distance measured parallel to the axis of the product from the top of the head to the bearing surface and shall include the thickness of the washer face. Raised grade and manufacturer's identification are excluded from head height.

**6.1.2 Round Heads.** Round head dimensions shall be in accordance with Table 7.

**6.1.2.1 Top of Head.** The top of the round head shall be spherical and may be underfilled within a circle approximating the nominal bolt diameter.

**6.1.2.2 Head Diameter.** The round head configuration shall have a head diameter in accordance with Table 7. The heads are not normally machined or trimmed, thus the circumference may be irregular with a rounded or flat edge.

### 6.2 Bearing Surface

Bearing surface shall be flat and washer faced. Diameter of bearing surface of the hex head design shall be equal to the maximum width across flats within a tolerance of -10%.

Thickness of the washer face shall be not less than 0.015 in. nor greater than 0.025 in. for bolt sizes  $\frac{3}{4}$  in. and smaller, and not less than 0.015 in. nor greater than 0.035 in. for sizes larger than  $\frac{3}{4}$  in.

The plane of the bearing surface shall be perpendicular to the axis of the body within the FIM limits specified for total runout. Measurement of FIM shall extend as close to the periphery of the bearing surface as possible while the bolt is being held in a collet or other gripping device at a distance of one bolt diameter from the underside of the head.

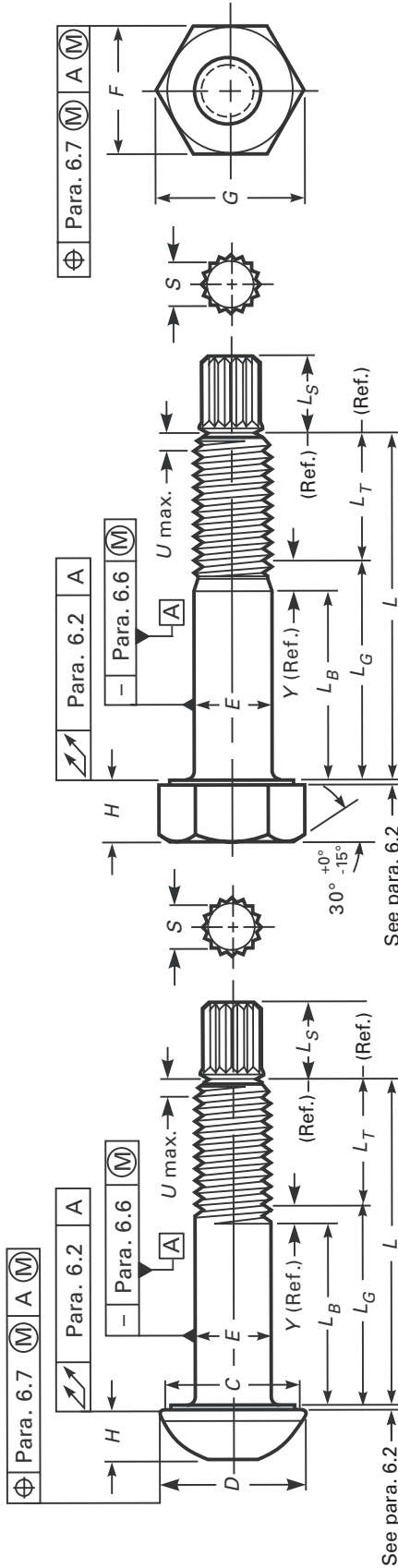

**Table 7 Dimensions of Twist-Off Type Tension Control Structural Bolts Heavy Hex Head and Round Head Configurations**

Nominal Size or Basic Major Diameter of Thread and Threads per inch	Heavy Hex Head			Heavy Hex and Round Head			Round Head			Spline			Center of First Groove to Fully Formed Thread, U		Transition Thread Length, Y		Total Runout of Bearing Surface FIM, [Note (4)]	
	Width Across Flats, F [Note (1)]		Width Across Corners, G	Head Height, H [Note (2)]		Full-Size Body Diam., E [Note (3)]		Bearing Diam., C	Head Diam., D [Note (5)]		Thread Length, L <sub>T</sub> [Note (6)]	Spline Length, L <sub>S</sub> [Note (7)]	Ref.	Ref.	Max.	Ref.	Ref.	Max.
	Max.	Min.		Max.	Min.	Max.	Min.		Max.	Ref.								
1/2-13	0.875	0.850	1.010	0.969	0.323	0.302	0.515	0.482	0.890	1.126	1.00	0.50	0.32	0.192	0.19	0.016		
5/8-11	1.062	1.031	1.227	1.175	0.403	0.378	0.642	0.605	1.102	1.313	1.25	0.60	0.43	0.227	0.22	0.019		
3/4-10	1.250	1.212	1.443	1.383	0.483	0.455	0.768	0.729	1.338	1.580	1.38	0.65	0.53	0.250	0.25	0.022		
7/8-9	1.438	1.394	1.660	1.589	0.563	0.531	0.895	0.852	1.535	1.880	1.50	0.72	0.61	0.278	0.28	0.025		
1-8	1.625	1.575	1.876	1.796	0.627	0.591	1.022	0.976	1.771	2.158	1.75	0.80	0.70	0.313	0.31	0.028		
1 1/8-7	1.812	1.756	2.093	2.002	0.718	0.658	1.149	1.098	1.991	2.375	2.00	0.90	0.80	0.367	0.34	0.032		
1 1/4-7	2.000	1.938	2.309	2.209	0.813	0.749	1.277	1.223	2.213	2.760	2.00	1.00	0.40	0.367	0.38	0.035		
1 3/8-6	2.188	2.119	2.526	2.416	0.878	0.810	1.404	1.345	2.434	2.910	2.25	1.10	1.00	0.417	0.44	0.038		
1 1/2-6	2.375	2.300	2.742	2.622	0.974	0.902	1.531	1.470	2.655	3.160	2.25	1.20	1.10	0.417	0.44	0.041		

- NOTES:  
 (1) See para. 6.1.1.2.  
 (2) See para. 6.1.1.4.  
 (3) See para. 6.5.  
 (4) See para. 6.2.  
 (5) See para. 6.1.2.2.  
 (6) See para. 6.11.  
 (7) See para. 6.8.  
 (8) See para. 6.9.

A die seam across the bearing surface is not permissible. The bearing surface shall be perpendicular to the axis of the body within a tolerance of 3 deg for 1 in. diameter and smaller, and 2 deg for diameters larger than 1 in.

### 6.3 Bolt Length

The bolt length shall be the distance measured parallel to the axis of the bolt from the bearing surface of the head to the center point of the groove through which shear will occur. Bolts are normally supplied in  $\frac{1}{4}$  in. length increments.

### 6.4 Length Tolerance

Bolt length tolerances shall be as tabulated below:

Nominal Bolt Size, in.	Nominal Bolt Length Tolerance (There is no tolerance plus.)	
	Through 6 in.	Over 6 in.
$\frac{1}{2}$	-0.12	-0.19
$\frac{5}{8}$	-0.12	-0.25
$\frac{3}{4}$ through 1	-0.19	-0.25
$1\frac{1}{8}$ through $1\frac{1}{2}$	-0.25	-0.25

### 6.5 Body Diameter

The body diameter,  $E$ , shall be in accordance with Table 7. Any swell or fin under the head or any die seam on the body should not exceed the basic bolt diameter by the following:

- 0.030 in. for sizes  $\frac{1}{2}$  in.
- 0.050 in. for sizes  $\frac{5}{8}$  in. and  $\frac{3}{4}$  in.
- 0.060 in. for sizes  $\frac{3}{4}$  in. through  $1\frac{1}{4}$  in.
- 0.090 in. for sizes over  $1\frac{1}{4}$  in.

### 6.6 Straightness

Shanks of bolts shall be straight within the following limits at MMC:

- for bolts with nominal lengths to and including 12 in., the maximum camber shall be 0.006 in. per inch (0.006 L) of bolt length.
- for bolts with nominal lengths over 12 in. to and including 24 in., the maximum camber shall be 0.008 in. per inch (0.008 L) of length.

A suggested gage and gaging procedure for checking bolt straightness is given in Appendix II of ASME B18.2.1.

### 6.7 True Position of Head

The axis of the head shall be located at true position with respect to the axis of the body (determined over a distance under the head equal to one diameter) within a tolerance zone having a diameter equivalent to 6% of the maximum width across flats, or head diameter at maximum material condition (MMC).

### 6.8 Spline

The spline dimensions and groove dimensions are reference dimensions and shall be at the discretion of the

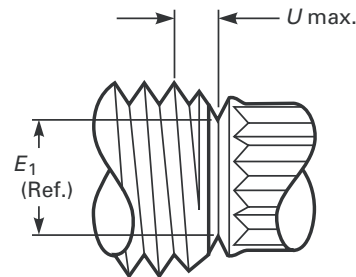

Fig. 1 Groove Diameter

manufacturer. Users should consult with the supplier to assure wrenchability. Reference dimensions for the spline length and width across flats are given in Table 7.

### 6.9 Point

Unless otherwise specified, bolts need not be pointed. The distance  $U$ , given in Table 7, is from the center of the groove to the first fully formed thread crest and shall not exceed 2.5 times the thread pitch. This shall be determined by measuring how far the point enters into a cylindrical NOT GO major diameter ring gage.

**6.9.1 Groove Diameter.** The groove diameter,  $E_1$ , is approximately equal to 80% of the thread maximum minor diameter, see Fig. 1. The actual  $E_1$  value shall be established by the manufacturer to assure proper function.

### 6.10 Threads

Threads, when rolled, shall be in the Unified Inch coarse or 8 thread series (UNRC or 8 UNR Series), Class 2A. Threads produced by other methods shall be Unified Inch coarse or 8 thread series (UNC or 8 UN Series), Class 2A. Acceptability of screw threads shall be determined based on System 21, ASME B1.3M, unless otherwise specified.

Unless otherwise specified, zinc coated bolts to be used with nuts which have been tapped oversize in accordance with Specification ASTM A 563, shall have Class 2A threads before mechanically deposited zinc coating.

### 6.11 Thread Length

The length of thread on bolts shall be controlled by the grip gaging length,  $L_G$  max., and the body length,  $L_B$  min.

Grip gaging length,  $L_G$  max., is the distance measured parallel to the axis of bolt from the underhead bearing surface to the face of a noncounterbored or noncountersunk standard GO thread ring gage, assembled by hand as far as the thread will permit. It shall be used as the criterion for inspection. The maximum grip gaging length, as calculated and rounded to two decimal places for any bolt not threaded full length, shall be equal to the

nominal bolt length minus the thread length ( $L_G \text{ max.} = L \text{ nom.} - L_T$ ). For bolts which are threaded full length,  $L_G \text{ max.}$  defines the unthreaded length under the head and shall not exceed the length of 2.5 times the thread pitch for sizes up to and including 1 in., and 3.5 times the thread pitch for sizes larger than 1 in.  $L_G \text{ max.}$  represents the minimum design grip length of the bolt and may be used for determining thread availability when selecting bolt lengths even though usable threads may extend beyond this point.

Thread length,  $L_T$ , is a reference dimension, intended for calculation purposes only, which represents the distance from the extreme end of the bolt to the last complete (full form) thread.

Body length,  $L_B$ , is the distance measured parallel to the axis of bolt from the underhead bearing surface to the last scratch of thread, or to the top of the extrusion angle. It shall be used as a criterion for inspection. The minimum body length, as calculated and rounded to two decimal places, shall be equal to the maximum grip gaging length minus the transition thread length ( $L_B = L_G \text{ max.} - Y$ ). Bolts of nominal lengths which have a calculated  $L_B$  length equal to or shorter than 2.5 times the thread pitch for sizes 1 in. and smaller, and 3.5 times the thread pitch for sizes larger than 1 in., shall be threaded for full length.

Transition thread length,  $Y$ , is a reference dimension, intended for calculation purposes only, which represents the length of incomplete threads and tolerance on grip gaging length.

### 6.12 Incomplete Thread Diameter

The major diameter of incomplete thread shall not exceed the actual major diameter of the full form thread.

### 6.13 Material and Mechanical Properties

Chemical and mechanical properties shall conform to ASTM F 1852.

### 6.14 Finish

Unless otherwise specified, bolts shall be supplied with a plain (as-processed) finish. If zinc coating is specified, all components of the assemblies shall be mechanically zinc coated in accordance with ASTM B 695, Class 50 Type I.

### 6.15 Workmanship

Bolts shall be free from burrs, seams, laps, loose scale, irregular surfaces, and any defects affecting serviceability. When control of surface discontinuities is required, the purchaser shall specify conformance to ASTM F 788/F 788M.

### 6.16 Designation

Twist-off-type tension control bolt assemblies include a bolt, nut, and washer and are designated in the following manner: quantity, size, including bolt diameter and length (without the spline end), name of product, head style, Type (1 or 3), specification, coating, and special requirements (if applicable).

EXAMPLE: 2,500 assemblies,  $\frac{3}{4} \times 2$ , twist off tension control bolt/nut/washer assemblies, round head, Type I, ASME B18.2.6, mechanically zinc coated to ASTM B 695.

### 6.17 Product Marking

All components shall be marked in accordance with ASTM F 1852.

**6.17.1 Identification Symbols.** Identification marking symbols on bolt heads shall be raised or indented at the manufacturer's option, unless otherwise specified. Markings shall be legible to the unaided eye with the exception of corrective lenses. When raised, the height of the marking may not exceed 0.015 in. over the specified maximum head height for bolts  $\frac{5}{8}$  in. and smaller. For bolts larger than  $\frac{5}{8}$  in., the marking may not project more than 0.030 in. over the specified maximum head height. When indented, the depth of the marking shall not reduce the load-carrying capability of the fastener.

### 6.18 Quality Assurance

The provisions of para. 2.7 shall apply.

### 6.19 Designated Characteristics

The designated characteristics of the bolts defined in the table below shall be inspected in accordance with ASME B18.18.2M.

Characteristic	Inspection Level
Threads	C
Width across corners	C
Head height	C
Grip length	C
Visual	C

For nondesignated characteristics, the provisions of ASME B18.18.1M shall apply. Should a nondesignated dimension be determined to be outside its specified limits, it shall be deemed conforming to this standard if the user, who is the installer, accepts the dimension based on fit, form, and function considerations. Where verifiable in-process inspection is used in accordance with ASME B18.18.3M or ASME B18.18.4M, the final inspection level sample sizes of those respective standards shall apply (para. 3.7.1 applies for the nut component, and para. 4.1.8.1 applies for the washer component).

# B18 AMERICAN NATIONAL STANDARDS FOR BOLTS, NUTS, RIVETS, SCREWS, WASHERS, AND SIMILAR FASTENERS

Small Solid Rivets .....	B18.1.1-1972 (R2001)
Large Rivets .....	B18.1.2-1972 (R2001)
Metric Small Solid Rivets .....	B18.1.3M-1983 (R2001)
Square and Hex Bolts and Screws (Inch Series) .....	B18.2.1-1996
Square and Hex Nuts (Inch Series) .....	B18.2.2-1987 (R1999)
Metric Hex Cap Screws .....	B18.2.3.1M-1999
Metric Formed Hex Screws .....	B18.2.3.2M-2005
Metric Heavy Hex Screws .....	B18.2.3.3M-1979 (R2001)
Metric Hex Flange Screws .....	B18.2.3.4M-2001
Metric Hex Bolts .....	B18.2.3.5M-1979 (R2001)
Metric Heavy Hex Bolts .....	B18.2.3.6M-1979 (R2001)
Metric Heavy Hex Structural Bolts .....	B18.2.3.7M-1979 (R2001)
Metric Hex Lag Screws .....	B18.2.3.8M-1981 (R1999)
Metric Heavy Hex Flange Screws .....	B18.2.3.9M-2001
Square Head Bolts (Metric Series) .....	B18.2.3.10M-1996 (R2003)
Metric Hex Nuts, Style 1 .....	B18.2.4.1M-2002
Metric Hex Nuts, Style 2 .....	B18.2.4.2M-2005
Metric Slotted Hex Nuts .....	B18.2.4.3M-1979 (R2001)
Metric Hex Flange Nuts .....	B18.2.4.4M-1982 (R1999)
Metric Hex Jam Nuts .....	B18.2.4.5M-1979 (R2003)
Metric Heavy Hex Nuts .....	B18.2.4.6M-1979 (R2003)
Fasteners for Use in Structural Applications .....	B18.2.6-2006
Metric 12-Spline Flange Screws .....	B18.2.7.1M-2002
Clearance Holes for Bolt, Screws, and Studs .....	B18.2.8-1999
Socket Cap, Shoulder, and Set Screws, Hex and Spline Keys (Inch Series) .....	B18.3-2003
Socket Head Cap Screws (Metric Series) .....	B18.3.1M-1986 (R2002)
Metric Series Hexagon Keys and Bits .....	B18.3.2M-1979 (R2003)
Hexagon Socket Head Shoulder Screws (Metric Series) .....	B18.3.3M-1986 (R2002)
Hexagon Socket Button Head Cap Screws (Metric Series) .....	B18.3.4M-1986 (R2002)
Hexagon Socket Flat Countersunk Head Cap Screws (Metric Series) .....	B18.3.5M-1986 (R2002)
Metric Series Socket Set Screws .....	B18.3.6M-1986 (R2002)
Round Head Bolts (Inch Series) .....	B18.5-1990 (R2003)
Metric Round Head Short Square Neck Bolts .....	B18.5.2.1M-1996 (R2003)
Metric Round Head Square Neck Bolts .....	B18.5.2.2M-1982 (R2000)
Round Head Square Neck Bolts With Large Head (Metric Series) .....	B18.5.2.3M-1990 (R2003)
Wood Screws (Inch Series) .....	B18.6.1-1981 (R2003)
Slotted Head Cap Screws, Square Head Set Screws, and Slotted Headless Set Screws (Inch Series) .....	B18.6.2-1998
Machine Screws and Machine Screw Nuts .....	B18.6.3-2003
Thread Forming and Thread Cutting Tapping Screws and Metallic Drive Screws (Inch Series) .....	B18.6.4-1998
Metric Thread-Forming and Thread-Cutting Tapping Screws .....	B18.6.5M-2000
Metric Machine Screws .....	B18.6.7M-1999
General Purpose Semi-Tubular Rivets, Full Tubular Rivets, Split Rivets and Rivet Caps .....	B18.7-1972 (R2001)
Metric General Purpose Semi-Tubular Rivets .....	B18.7.1M-1984 (R2000)
Clevis Pins and Cotter Pins (Inch Series) .....	B18.8.1-1994 (R2000)
Taper Pins, Dowel Pins, Straight Pins, Grooved Pins, and Spring Pins (Inch Series) .....	B18.8.2-2000
Spring Pins: Coiled Type, Spring Pins: Slotted, Machine Dowel Pins: Hardened Ground, and Grooved Pins (Metric Series) .....	B18.8.100M-2000
Cotter Pins, Headless Clevis Pins, and Headed Clevis Pins (Metric Series) .....	B18.8.200M-2000
Plow Bolts (Inch Series) .....	B18.9-1996 (R2003)
Track Bolts and Nuts .....	B18.10-1982 (R2000)
Miniature Screws .....	B18.11-1961 (R2000)
Glossary of Terms for Mechanical Fasteners .....	B18.12-2001
Screw and Washer Assemblies — Sems (Inch Series) .....	B18.13-1996 (R2003)
Screw and Washer Assemblies: Sems (Metric Series) .....	B18.13.1M-1998 (R2003)
Forged Eyebolts .....	B18.15-1985 (R2003)
Metric Lifting Eyes .....	B18.15M-1998 (R2004)



Prevailing-Torque Type Steel Metric Hex Nuts and Hex Flange Nuts .....	B18.16M-2004
Inspection and Quality Assurance for General Purpose Fasteners .....	B18.18.1M-1987 (R1999)
Inspection and Quality Assurance for High-Volume Machine Assembly Fasteners .....	B18.18.2M-1987 (R1999)
Inspection and Quality Assurance for Special Purpose Fasteners .....	B18.18.3M-1987 (R1999)
Inspection and Quality Assurance for Fasteners for Highly Specialized Engineered Applications .....	B18.18.4M-1987 (R1999)
Inspection and Quality Assurance Plan Requiring In-Process Inspection and Controls.....	B18.18.5M-1998 (R2003)
Quality Assurance Plan for Fasteners Produced in a Third Party Accreditation System .....	B18.18.6M-1998 (R2003)
Quality Assurance Plan for Fasteners Produced in a Customer Approved Control Plan .....	B18.18.7M-1998 (R2003)
Lock Washers (Inch Series).....	B18.21.1-1999
Lock Washers (Metric Series) .....	B18.21.2M-1999
Metric Plain Washers.....	B18.22M-1981 (R2000)
Plain Washers .....	B18.22.1-1965 (R2003)
Part Identifying Number (PIN) Code System for B18 Fastener Products .....	B18.24-2004
Square and Rectangular Keys and Keyways.....	B18.25.1M-1996 (R2003)
Woodruff Keys and Keyways .....	B18.25.2M-1996 (R2003)
Square and Rectangular Keys and Keyways: Width Tolerances and Deviations Greater Than Basic Size .....	B18.25.3M-1998 (R2003)
Tapered and Reduced Cross Section Retaining Rings (Inch Series) .....	B18.27-1998
Helical Coil Screw Thread Inserts — Free Running and Screw Locking (Inch Series).....	B18.29.1-1993 (R2002)
Helical Coil Screw Thread Inserts: Free Running and Screw Locking (Metric Series) .....	B18.29.2M-2005
Open-End Blind Rivets With Break Mandrels (Metric Series) .....	B18.30.1M-2000
Metric Continuous and Double-Ended Studs.....	B18.31.1M-2005

The ASME Publications Catalog shows a complete list of all the Standards published by the Society. For a complimentary catalog, or the latest information about our publications, call 1-800-THE-ASME (1-800-843-2763).

# ASME B18.2.6-2006

ISBN 0-7918-3009-8

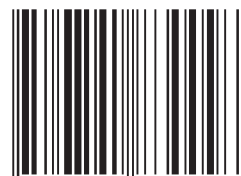

9 780791 830093



M16106